

# UC-7408 Series

**RISC-based data acquisition computers with 8 serial ports, 8 DI/DO channels, dual LANs, PCMCIA, CompactFlash**



- > Intel XScale IXP-422/425, 266/533 MHz processor
- > 128 MB RAM on-board, 32 MB flash disk
- > 8 RS-232/422/485 serial ports
- > 8-ch digital input and 8-ch digital output (TTL Signal)
- > Dual 10/100 Mbps Ethernet for network redundancy
- > CompactFlash socket for storage expansion
- > PCMCIA supporting WLAN, GPRS, UMTS, HSDPA
- > Ready-to-run Linux or WinCE 5.0 platform
- > DIN-rail or wall-mount installation
- > Robust, fanless design
- > -40 to 75°C wide temperature models available

The certification logos shown here apply to some or all of the products in this section. Please see the **Specifications** section or Moxa's website for details.



16

RISC-based Computers > UC-7408 Series

## Overview

The UC-7408 is a data acquisition embedded computer for embedded applications that features 8 RS-232/422/485 serial ports, 8-ch digital input, 8-ch digital output, dual 10/100 Mbps, PCMCIA interface for wireless LAN communication, and CompactFlash slot for mass storage disk expansion.

In addition to the 8 RS-232/422/485 serial ports, the UC-7408 also has 8 digital input and 8 digital output channels, making it suitable as a data acquisition solution.

The digital I/O feature of the UC-7408 provides users with the convenience of connecting digital devices to a front-end embedded computer. The UC-7408 can be used for on/off event handling by reading the state change of the digital input signal. In addition, output signals from external digital devices can be imported in through

the UC-7408's digital input channels, and the UC-7408 can be programmed to take immediate action when it detects a change in the state of the signal.

The digital output channels on the UC-7408 can connect to devices and trigger digital output signals to control external digital devices. With the digital I/O feature, Moxa's embedded computers support both data acquisition and protocol conversion through the RS-232/422/485 serial ports, and simple I/O control with the digital I/O signals.

Choose a pre-installed open standard Linux OS or the more common WinCE OS. Software written for a desktop PC can be easily ported to the UC-7408 platform by using a common compiler, without needing to modify the code. All the software you develop for your own applications can be stored in the UC-7408's flash memory.

## Typical Application

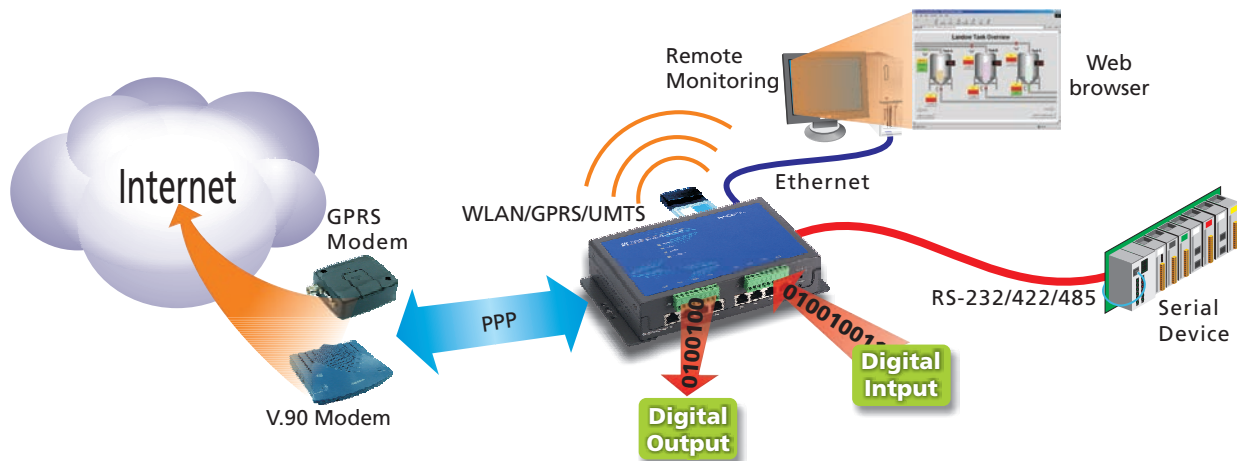

## Appearance

### Front View

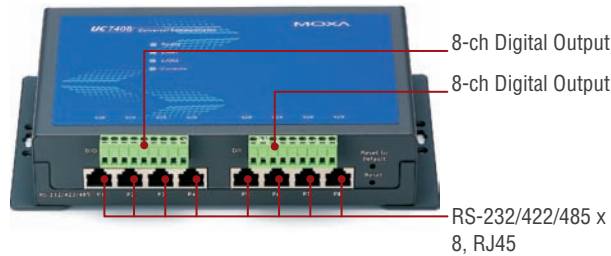

### Back View

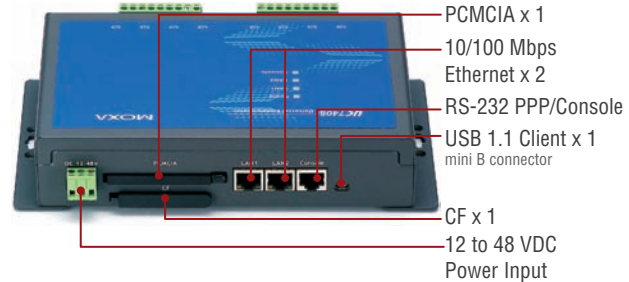

## Hardware Specifications

### Computer

#### CPU:

UC-7408: Intel XScale IXP-422 266 MHz  
UC-7408 Plus: Intel XScale IXP-425 533 MHz

**OS (pre-installed):** Embedded Linux or Windows CE 5.0

**DRAM:** 128 MB onboard (256 MB for ODM)

**Flash:** 32 MB onboard

**PCMCIA:** Cardbus card and 16-bit PCMCIA 2.1/JEIDA 4.2 card

**Storage Expansion:** Full function CompactFlash x 1

**USB:** USB 2.0 hosts x 2 (UC-7408 Plus only)

**DI/DO:** DI x 8, DO x 8, TTL (3.3V)

### LAN Interface

**Ethernet:** 10/100 Mbps x 2, RJ45 connectors

**Magnetic Isolation Protection:** 1.5 KV built-in

### Serial Interface

**Number of Ports:** 8

**Serial Standards:** RS-232/422/485, software-selectable

**Connectors:** 8-pin RJ45

**ESD Protection:** 15 KV for all signals

**Console Port:** RS-232 x 1, RJ45 connector, supports PPP

### Serial Communication Parameters

**Data Bits:** 5, 6, 7, 8

**Stop Bits:** 1, 1.5, 2

**Parity:** None, Even, Odd, Space, Mark

**Flow Control:** RTS/CTS, XON/XOFF, ADDC™ (automatic data direction control) for RS-485

**Baudrate:** 50 bps to 921.6 Kbps (non-standard baudrates supported; see user's manual for details)

### Serial Signals

**RS-232:** TxD, RxD, DTR, DSR, RTS, CTS, DCD, GND

**RS-422:** TxD+, TxD-, RxD+, RxD-, GND

**RS-485-4w:** TxD+, TxD-, RxD+, RxD-, GND

**RS-485-2w:** Data+, Data-, GND

### Digital Input

**Input Channels:** 8

**Input Voltage:**

Logic 0: 0-0.8V  
Logic 1: 2.0-5.5V

**Protection:** Over-current limit (-24 mA)

### Digital Output

**Output Channels:** 8

**Output Current:** 24 mA

**Output Voltage:**

Logic 0: 0-0.55V  
Logic 1: 2.5-3.3V

### LEDs

**System:** OS Ready x 1, Console (TxD/RxD) x 1

**LAN:** 10M/100M x 2

**Serial:** TxD, RxD (8 of each)

### Physical Characteristics

**Housing:** SECC sheet metal (1 mm)

**Weight:** 870 g

**Dimensions:** 197 x 44 x 125 mm (7.76 x 1.73 x 4.92 in)

**Mounting:** DIN-Rail, wall

### Environmental Limits

**Operating Temperature:**

Standard models: -10 to 60°C (14 to 140°F)  
Wide temp.models: -40 to 75°C (-40 to 167°F)

**Operating Humidity:** 5 to 95% RH

**Storage Temperature:** -20 to 80°C (-4 to 176°F)

**Anti-vibration:** 1G @ IEC-68-2-6, sine wave, 5-500 Hz, 1 Oct./min, 1 hr/axis

**Anti-shock:** 5G @ IEC-68-2-27, half sine wave, 30 ms

### Power Requirements

**Input Voltage:** 12 to 48 VDC

**Power Consumption:** 628 mA @ 12 VDC (8 watts)

### Regulatory Approvals

**EMC:** CE (EN55022 Class A, EN61000-3-2 Class A, EN61000-3-3, EN55024), FCC (Part 15 Subpart B, CISPR 22 Class A)

**Safety:** UL/cUL (UL60950-1, CSA C22.2 No. 60950-1-03), TÜV (EN60950-1)

### Reliability

**Alert Tools:** Built-in buzzer and RTC (real-time clock)

**Automatic Reboot Trigger:** Built-in WDT (watchdog timer)

### Warranty

**Warranty Period:** 5 years

**Details:** See [www.moxa.com/warranty](http://www.moxa.com/warranty)

### Pin Assignment

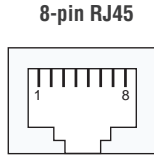

PIN	RS-232	RS-422/RS-485-4w	RS-485
1	DSR	---	---
2	RTS	TxD+	---
3	GND	GND	GND
4	TxD	TxD-	---
5	RxD	RxD+	Data+
6	DCD	RxD-	Data-
7	CTS	---	---
8	DTR	---	---

### H/W Block Diagram

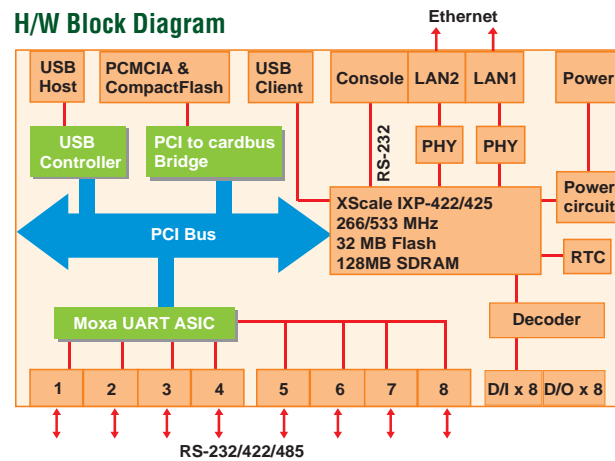

## Software Specifications

### Linux

**Kernel Version:** 2.4.18 or 2.6.10 (Plus version)

**Protocol Stack:** TCP, UDP, IPv4, SNMP V1, ICMP, IGMP, ARP, HTTP, CHAP, PAP, SSH 1.0/2.0, SSL, DHCP, NTP, NFS, SMTP, Telnet, FTP, PPP, PPPoE

**File System:** JFFS2 (on-board flash)

**System Utilities:** bash, busybox, tinylogin, telnet, ftp, scp

**Supporting Services and Daemons:**

- telnetd: Telnet Server daemon
- ftpd: FTP server daemon
- sshd: Secure shell server
- Apache: Web server daemon, supporting PHP and XML
- OpenVPN: Virtual private network service manager
- iptables: Firewall service manager
- pppd: dial in/out over serial port daemon & PPPoE
- snmpd: snmpd agent daemon
- inetd: TCP server manager program

**Application Development Environment:**

- Moxa Linux API Library for device control
- Linux Tool Chain: Gcc, Glibc, GDB

### Windows Embedded CE 5.0

**System Utilities:** Windows command shell, telnet, ftp, web-based administration manager

**File System:** FAT (on-board flash)

**Protocol Stack:** TCP, UDP, IPv4, SNMP, ICMP, IGMP, ARP, HTTP, CHAP, PAP, SSL, DHCP, SNTP, SMTP, Telnet, FTP, PPP

**Supporting Services and Daemons:**

- Telnet Server: Allows remote administration through a standard telnet client.
- FTP Server: Used for transferring files to and from remote computer systems over a network.
- Web Server (httpd): WinCE IIS, including ASP, ISAPI Secure Socket Layer support, SSL 2, SSL 3, and Transport Layer Security (TLS/SSL 3.1) public key-based protocols, and Web Administration ISAPI Extensions.
- Dial-up Networking Service: RAS client API and PPP, supporting Extensible Authentication Protocol (EAP) and RAS scripting.

**Application Development Environment:**

- Moxa WinCE 5.0 SDK
- C Libraries and Run-times
- Component Services (COM and DCOM)
- Microsoft Foundation Classes (MFC)
- Microsoft® .NET Compact Framework 2.0 SP2
- XML, including DOM, XQL, XPATH, XSLT, SAX2
- SOAP Toolkit
- Winsock 2.2

## Ordering Information

### Available Models

**UC-7408-LX:** RISC-based IXP-422 embedded computer with 8 serial ports, 8 DI channels, 8 DO channels, dual LANs, PCMCIA, CompactFlash, Linux 2.4 (standard operating temperature: -10 to 60°C)

**UC-7408-LX Plus:** RISC-based IXP-425 embedded computer with 8 serial ports, 8 DI channels, 8 DO channels, dual LANs, PCMCIA, CompactFlash, USB, Linux 2.4 (standard operating temperature: -10 to 60°C)

**UC-7408-CE:** RISC-based IXP-422 embedded computer with 8 serial ports, 8 DI channels, 8 DO channels, dual LANs, PCMCIA, CompactFlash, WinCE 5.0 (standard operating temperature: -10 to 60°C)

**UC-7408-T-LX:** RISC-based IXP-422 embedded computer with 8 serial ports, 8 DI channels, 8 DO channels, dual LANs, PCMCIA, CompactFlash, Linux 2.4 (wide operating temperature: -40 to 75°C)

**UC-7408-T-LX Plus:** RISC-based IXP-425 embedded computer with 8 serial ports, 8 DI channels, 8 DO channels, dual LANs, PCMCIA, CompactFlash, Linux 2.4 (wide operating temperature: -40 to 75°C)

**UC-7408-T-CE:** RISC-based IXP-422 embedded computer with 8 serial ports, 8 DI channels, 8 DO channels, dual LANs, PCMCIA, CompactFlash, WinCE 5.0 (wide operating temperature: -40 to 75°C)

### Package Checklist

- UC-7408 embedded computer
- Wall mounting kit
- DIN-Rail mounting kit
- Ethernet cable: RJ45 to RJ45 cross-over cable, 100 cm
- CBL-RJ45F9-150: 8-pin RJ45 to DB9 female console port cable, 150 cm
- CBL-RJ45M9-150: 8-pin RJ45 to DB9 male serial port cable, 150 cm
- Universal power adaptor (including terminal block to power jack converter)
- Document and Software CD
- Quick Installation Guide (printed)
- Warranty Card