

IA3341

RISC-based embedded computer with 2 serial ports, 4 DIs, 4 DOs, 2 AIs, 2 thermocouples, dual LANs, SD, Linux



- > MOXA ART 32-bit ARM 9 industrial processor
- > 64 MB RAM, 16 MB Flash onboard
- > 2 software selectable RS-232/422/485 serial ports
- > 50 bps to 921.6 Kbps serial speed (non-standard baudrates supported)
- > 4 DIs and 4 DOs with 3 KV digital isolation protection
- > 2 AIs and 2 thermocouple inputs; sensor types J, K, T, E, R, S, B, N
- > Dual 10/100 Mbps Ethernet ports for network redundancy
- > SD socket for storage expansion
- > USB 2.0 host
- > Supports Modbus TCP library to retrieve AI and thermocouple data
- > Ready-to-run Linux Kernel 2.6 platform
- > DIN-Rail and wall mount installation
- > Robust, fanless design



Overview

The IA240/241 embedded computers are designed for industrial automation applications. The computers feature 4 RS-232/422/485 serial ports, dual LANs, 4 digital input channels, 4 digital output channels, and a PCMCIA cardbus and SD socket in a compact, IP30 protected, industrial-strength rugged housing.

The IA240/241's vertical DIN-rail form factor makes it easy to install the computers in a small cabinet. This space-saving solution also facilitates easy wiring, making the IA240/241 a great choice as front-end embedded controllers for industrial applications.

Wide temperature models of the IA240/241 are also available. The IA240-T and IA241-T can operate reliably in a temperature range from -40 to 75°C, making them appropriate for harsh industrial automation environments.

The industrial design of the IA240/IA241 provides a robust, reliable computing platform. Due to their RISC-based architecture, the IA240/IA241 computers will not generate a lot of heat, making them ideal for industrial automation environments.

Appearance

Front View

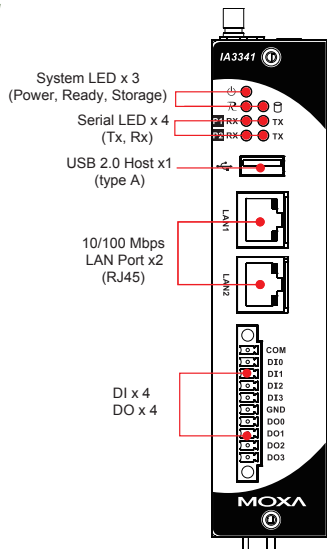

Top and Bottom Views

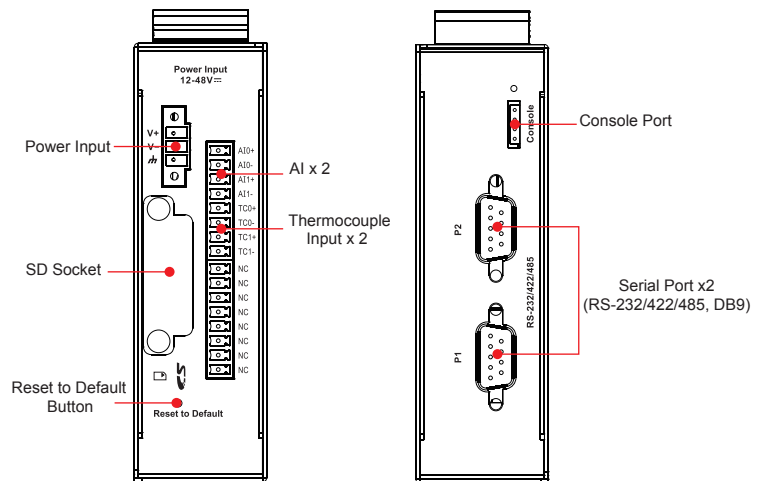

Hardware Specifications

Computer

CPU: MOXA ART ARM9 32-bit RISC CPU, 192 MHz

OS (pre-installed): Embedded Linux

DRAM: 64 MB onboard

Flash: 16 MB onboard

USB: USB 2.0 host x 1 (type A connector)

Storage

Storage Expansion: SD slot

Ethernet Interface

LAN: 2 auto-sensing 10/100 Mbps ports (RJ45)

Magnetic Isolation Protection: 1.5 KV built-in

Serial Interface

Serial Standards: 2 RS-232/422/485 ports, software-selectable (DB9 male)

ESD Protection: 15 KV for all signals

Console Port: RS-232 (TxD, RxD, GND), 4-pin header output (115200, n, 8, 1)

Serial Communication Parameters

Data Bits: 5, 6, 7, 8

Stop Bits: 1, 1.5, 2

Parity: None, Even, Odd, Space, Mark

Flow Control: RTS/CTS, XON/XOFF, ADDC® (automatic data direction control) for RS-485

Baudrate: 50 bps to 921.6 Kbps (supports non-standard baudrates; see user's manual for details)

Serial Signals

RS-232: TxD, RxD, DTR, DSR, RTS, CTS, DCD, GND

RS-422: TxD+, TxD-, RxD+, RxD-, GND

RS-485-4w: TxD+, TxD-, RxD+, RxD-, GND

RS-485-2w: Data+, Data-, GND

Digital Input

Input Channels: 4, source type

Input Voltage: 0 to 30 VDC

Digital Input Levels for Dry Contacts:

- Logic level 0: Close to GND
- Logic level 1: Open

Digital Input Levels for Wet Contacts:

- Logic level 0: +2 V max.
- Logic level 1: +4 V to +30 V

Connector Type: 10-pin screw terminal block (4 points, COM, GND)

Isolation: 3 KV digital isolation

Digital Output

Output Channels: 4, sink type, keeps output status after hot system reset

Output Range: 5 to 30 VDC at open collector to 30 V

Max. Load: 30 mA

Power Dissipation: 300 mW

Connector Type: 10-pin screw terminal block (4 points, GND)

Isolation: 3 KV digital isolation

Analog Input

Input Channels: 2

Resolution: 16 bits

I/O Mode: Voltage/Current

Input Range: 0-10 V, 4-20 mA

Accuracy:

- ±0.1% FSR @ 25°C
- ±0.3% FSR @ 10°C and 60°C

Sampling Rate: 12 samples/sec

Input Impedance: 200K ohms

Thermocouple Input

Input Channels: 2

Sensor Types: J, K, T, E, R, S, B, N

Sampling Rate: 12 samples/sec

Resolution: 16 bits

Accuracy:

- ±0.1% FSR @ 25°C
- ±0.3% FSR @ 10°C and 60°C

Input Impedance: 1M ohms

LEDs

System: Power, Ready, Storage

LAN: 10M/Link x 2, 100M/Link x 2 (on connector)

Serial: TxD x 2, RxD x 2

Reset Button: Supports "Reset to Factory Default"

Physical Characteristics

Housing: SECC sheet metal (1 mm)

Weight: 585 g

Dimensions: 116 x 35 x 146 mm (2.95 x 1.38 x 3.71 in)

Mounting: DIN-Rail, wall

Environmental Limits

Operating Temperature: -10 to 60°C (14 to 140°F)

Storage Temperature: -20 to 80°C (-4 to 176°F)

Ambient Relative Humidity: 5 to 95% (non-condensing)

Anti-vibration: 2 g rms @ IEC 60068-2-34, random wave, 5-500 Hz, 1 hr per axis

Anti-shock: 20 g @ IEC 60068-2-27, half sine wave, 11 ms

Power Requirements

Input Voltage: 12 to 48 VDC (3-pin terminal block, V+, V-, SG)

Power Consumption:

5 W (with no load on the USB port)

• 106 mA @ 48 VDC

• 191 mA @ 24 VDC

• 351 mA @ 12 VDC

8.5 W (with load on the USB port)

• 176 mA @ 48 VDC

• 330 mA @ 24 VDC

• 661 mA @ 12 VDC

Standards and Certifications

Safety: UL 60950-1, EN 60950-1, CCC (GB4943, GB9254, GB17625.1)

EMC: EN 55022 Class A, EN 61000-3-2 Class A, EN 61000-3-3, EN

55024, FCC Part 15 Subpart B Class A

Green Product: RoHS, CRoHS, WEEE

Reliability

Alert Tools: Built-in buzzer and RTC (real-time clock)

Automatic Reboot Trigger: Built-in WDT (watchdog timer)

MTBF (mean time between failures): 333,363 hrs

Warranty

Warranty Period: 5 years

Details: See www.moxa.com/warranty

: Software Specifications

Linux

OS: Linux 2.6.9

File System: JFFS2 (for on-board flash)

Internet Protocol Suite: TCP, UDP, IPv4, SNMPv1, ICMP, ARP, HTTP, CHAP, PAP, DHCP, NTP, NFS, SMTP, Telnet, FTP, TFTP, PPP, PPPoE

Internet Security: OpenVPN, iptables firewall

Web Server (Apache): Allows you to create and manage web sites

Terminal Server (SSH): Provides secure encrypted communications between two un-trusted hosts over an insecure network

Dial-up Networking: PPP Daemon for Linux that allows Unix machines to connect to the Internet through dialup lines, using the PPP protocol, as a PPP server or client. Works with 'chat', 'dip', and 'diald', among (many) others. Supports IP, TCP, UDP, and (for Linux) IPX (Novell).

Watchdog: Features a hardware function to trigger system reset in a user specified time interval (Moxa API provided)

Application Development Software:

- Moxa API Library (Watchdog timer, Moxa serial I/O control, Moxa DI/DO API)

- GNU C/C++ cross-compiler

- GNU C library

- GDB source-level debugging server

Software Protection: Encryption tool for user executable files (based on patented Moxa technology)

Dimensions

Unit: mm (inch)

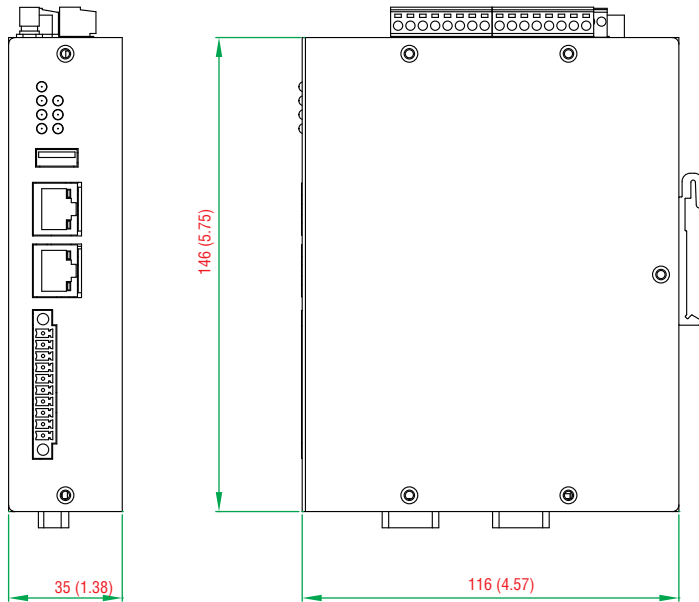

: Ordering Information

Available Models

IA3341-LX: RISC-based embedded computer with 2 serial ports, 4 DIs, 4 DOs, 2 AIs, 2 thermocouples, dual LANs, SD, Linux

Package Checklist

- IA3341-LX embedded computer
- Wall mounting kit
- Ethernet cable: RJ45 to RJ45 cross-over cable, 100 cm
- CBL-4PINDB9F-100: 4-pin pin header to DB9 female console port cable, 100 cm
- Terminal block to power jack converter
- Documentation and software CD
- Quick installation guide (printed)
- Warranty card